

TURNSTILE
BR2-T
VERSION 2.0

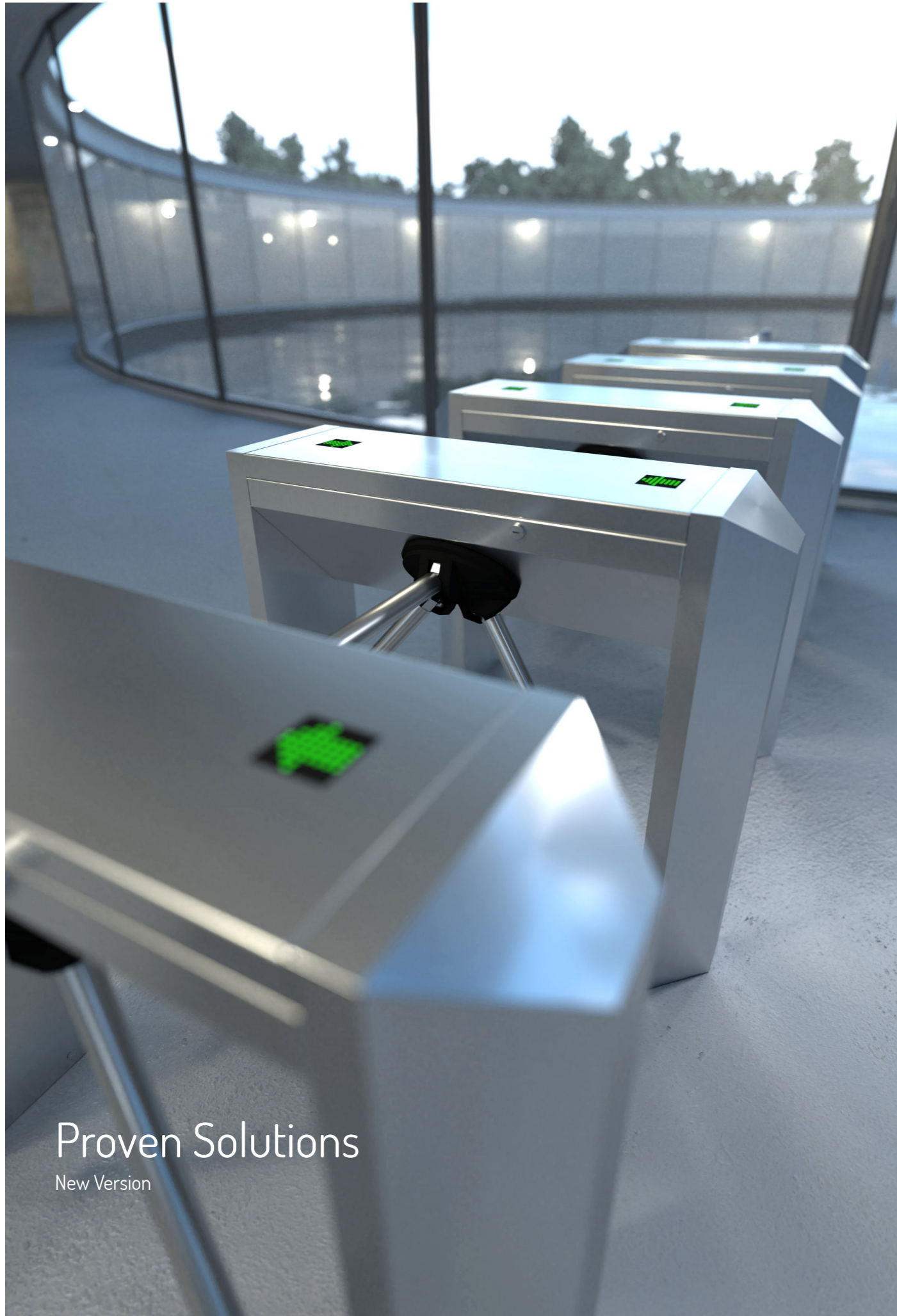



Proven Solutions
New Version

Quick and Easy Setup



DEVICE DESCRIPTION

The device designed to assist pedestrian access control at guarded passage ways inside buildings.

Examples of use:

- points of ticket control and access control for passenger traffic,
- airports/seaports,
- passages for authorised personnel, directing passenger traffic,
- points of access control in secured buildings (e.g. state offices such as border crossing points, other services),
- points of ticket control and fees at museums, theatres, cinemas, exhibitions, fair areas, show facilities, paid toilets, points of ticket control at sports facilities, e.g. swimming pools, stadiums, other sports and show facilities,
- access and time attendance control points in working places, e.g. offices, dedicated areas in factories.



Safety With Style

Versatile Solutions

For Access Control Industry



DEVICE DESCRIPTION

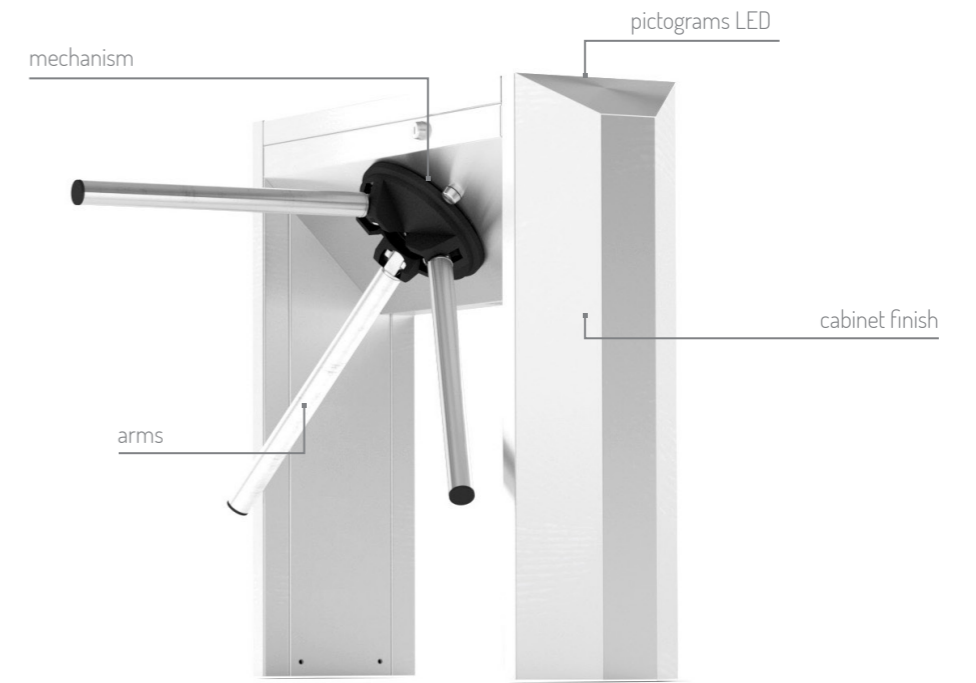

FINISH OPTIONS



Stainless steel - INOX AISI 304



RAL 9006

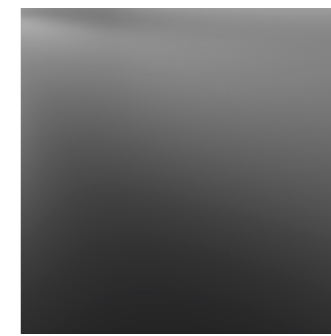

RAL 7016



RAL 5010



RAL 6002



RAL 9003

Standard finish

Non-standard colour/non-standard finishing

FUNCTIONS



1

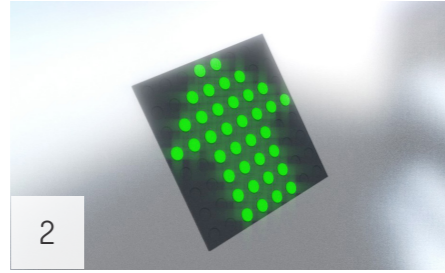

2

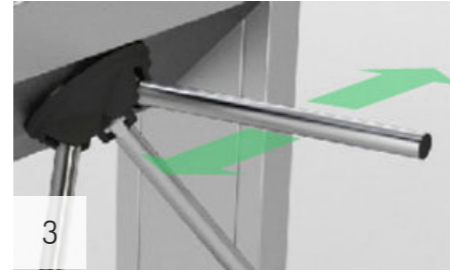

3

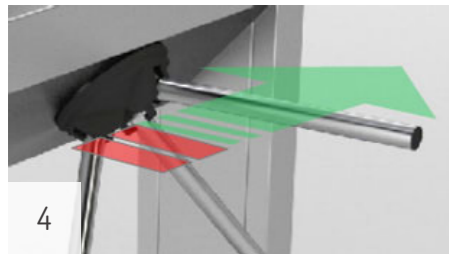

4



5

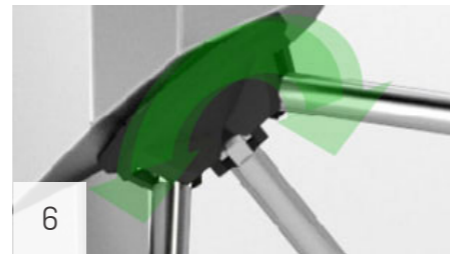

6

1. EASY SETUP

A control panel equipped with a display and a multi-function selector allows easy setup of functions and operating modes.

2. LED PICTOGRAMS

Led pictograms show active/inactive traffic directions in the passage. The red color shows the inactive/blocked traffic direction (the device blocks the passage). The green color shows active/unblocked traffic direction.

3. WORK MODES

The device has a number of operating modes, e.g. uni- or bi- directional traffic control.

4. PRECISE MEASUREMENT SYSTEM

The device is equipped with an electronic rotor position detection system that allows the control unit to precisely control the locking system as well as smooth motion of the arms (available in the model with an electro-mechanical arm movement booster).

5. ARM-DROP SYSTEM (OPTIONAL)

Automatic arm-drop system in case of a power failure (this function is available in models equipped with the arm-drop module).

6. ARM MOTION BOOSTER

The device is equipped with an electromechanical arm rotation booster. It consists of a motor drive, safety clutch and speed transmission. The motion speed can be varied for smooth operation depending on the rotor position.

TECHNICAL SPECIFICATIONS

MECHANISM

Designed for continuous operation.
Mechanisms allow 1200 cycles per hour.

MECHANISM [BR2] is also equipped with:

- double blockade system,
- additional mechanical unlocking of blockade systems.

ELECTRONIC SYSTEM

- Control input (0V signal) for each traffic direction separately
- Feedback signal output (0V signal) to report a passing individual based on an authorization signal,
- Higher priority inputs to deactivate selected passage sections (e.g. from a building management system),
- Top priority input to clear/open a passage section (e.g. from the firefighting system),
- Functions: remembering steering signals during the working cycle, sound signalling, diode signalling, automatic calibration

DEVICE SYMBOL - NON DROP ARM VERSION

Model	Type of finishing
BR2-T	INOX/RAL ...

DEVICE SYMBOL - DROP ARM VERSION

Model	Type of finishing
BR2-T-DA	INOX/RAL ...

Examples:

- BR2-T - RALS010 - BR2-T turnstile with steel cabinet in RALS010 black powder coating finish.
- BR2-T-DA-INOX - BR2-T turnstile with arm-drop function and cabinet finished in AISI304 ground steel.

SPECIFICATIONS

Power supply voltage:	24 V AC
Peak current:	120 W
Minimum power consumption:	5 A
Control signal:	max. 0.5 sec
Feedback signal:	0V
Operating temperature:	-20° to +50° C [-4° to 122°F]
Storage temperature:	-30° to +60° C [-22° to 140°F]
Relative humidity:	10-80%
Operating environment:	inside/outside of buildings
IP protection rate:	IP 40
Net weight:	-60kg [132 lb]

OPTIONAL EQUIPMENT*

Name	Description
Power supply	Power supply 230/24V or 110/24V
Control panel	Control panel for manual traffic control

* Optional equipment is not included with the device.



Additional materials and how-to videos available at www.gastopgroup.com

All information given herein is valid at time of publication. GASTOP reserves the right to introduce changes to this offer, concerning both models as well as their construction and equipment. This document does not constitute an offer as understood by law and is published solely for the purpose of information. Optional equipment presented in this brochure may not be available. Product photos and visualizations presented herein may not accurately show technologies in use, properties of materials or colors. Please refer to an authorized distributor or directly to the device manufacturer for detailed information on the above mentioned parameters.

DIMENSIONS

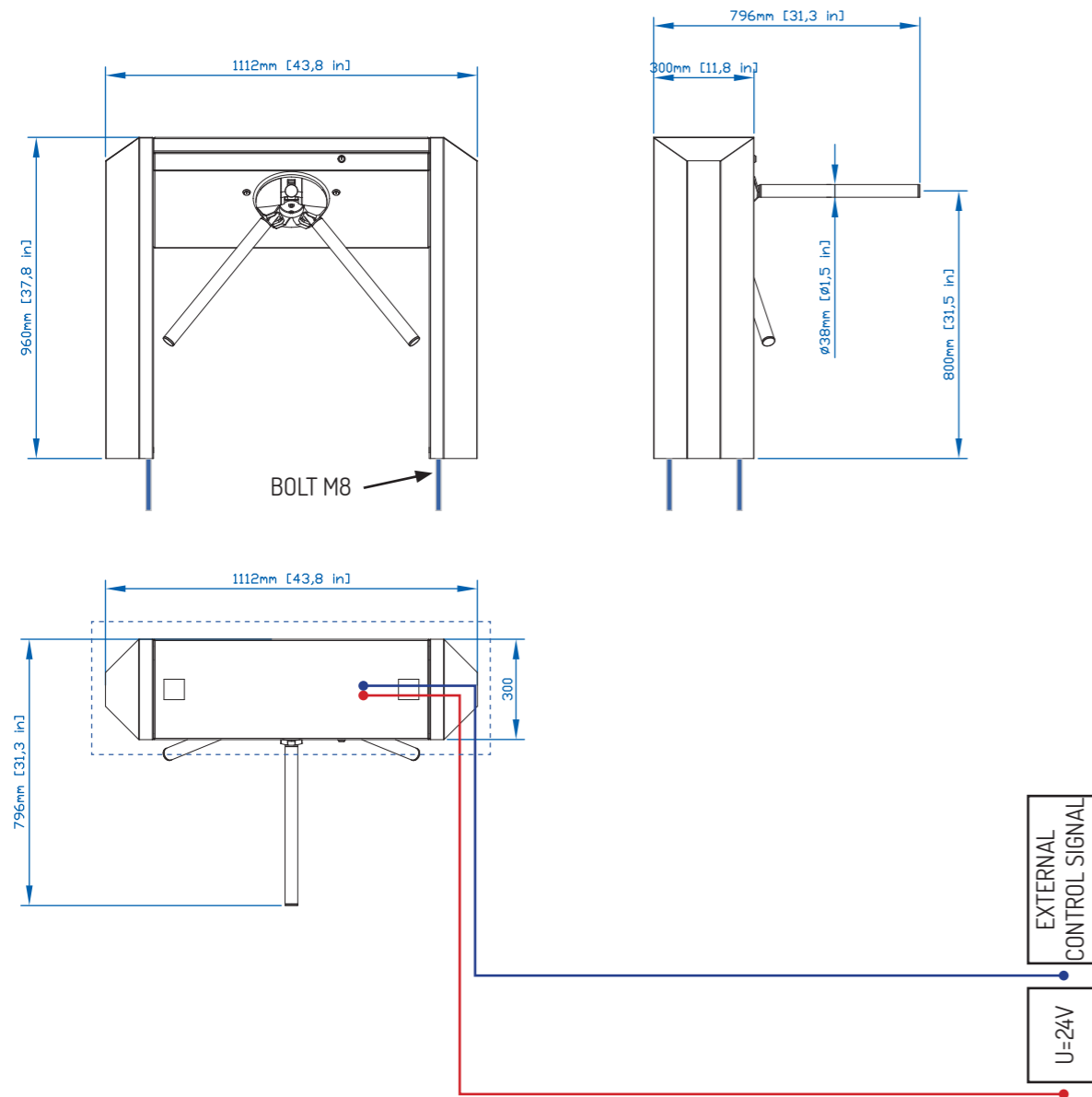

KEY:

- External control signal - S/UTP cable
- 24 V supply - 0MY wire 3x1,5mm
- Foundation

Notes:



WWW.GASTOPGROUP.COM
/ EN / DE / FR / PL / SV / RU / HE /

Distributor

MADE IN E.U.